

Pathway to 1 Star Executive

Our Career Plan is a simple plan to understand, once you realize advancing in rank is simply duplication. To become a 1 Star Executive you need 3 qualified Sales Associates in a month, and to complete the structure you see below. Sales Associates need to have at least 150 PQV, and 3 Customers or Associates each above 50 PQV. The other requirement to 1 Star Executive is to have 5400 in Group Qualifying Volume in your first 3 levels. Customer and Associate orders all count toward this. A qualified 1 Star Executive should make about \$1000-\$1500 a month.

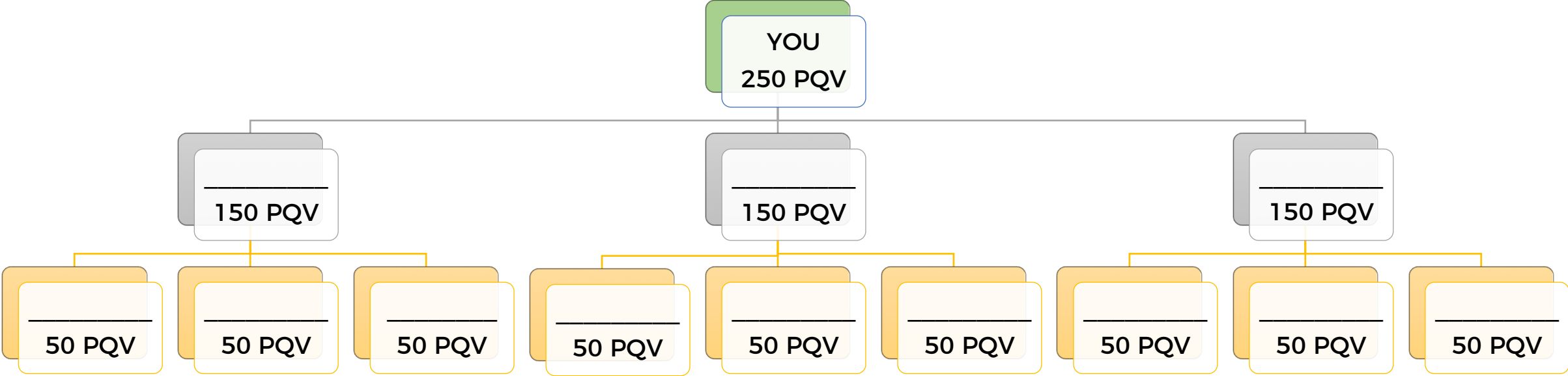

Because you also need to have 5400 in Group Qualifying Volume in your 1st 3 levels, completing the above structure is just one step. The other step is to enroll more Customers and Associates to build your team, which adds sales volume. Personally enrolling 12 Customers or Distributors who purchase at least \$100 in QV will move you toward your goal. Signing up Business Builders who purchase a CEO MEGA Pack (500QV) will help you reach 1 Star even faster.

- | | | | |
|----------|----------|----------|-----------|
| 1. _____ | 4. _____ | 7. _____ | 10. _____ |
| 2. _____ | 5. _____ | 8. _____ | 11. _____ |
| 3. _____ | 6. _____ | 9. _____ | 12. _____ |